



SED-64 4G

September 2024, V052

INSTALLATION & USER MANUAL

WARNING

This equipment must be installed by a qualified installer

WWW.SECENG.COM.AU

Sydney, Australia

This manual is subject to copyright Rev 2024.06.04

WARRANTY & LIABILITY INFORMATION

Please Read First

- The SED-64 is only to be installed by an authorised service person.
- The supplied 16V AC plug pack must only be connected to a 240V AC outlet socket with a **protective earth connection**.
- Do not wire any sperate AC transformer or power supply in parallel with this product. **IT WILL VOID YOUR WARRANTY**
- Ensure the unit is mounted in a secure location and with the antenna in an **upright** position.
- Cover the antenna in 20mm conduit when installing in exposed places.
- Disconnect all telecommunication connectors before removing the power supply cord or protective earth.

PRODUCT WARRANTY

This product is covered by a 12 month, **Back-to-Base Warranty**, from the date of purchase and proof of purchase should be supplied. The warranty does not cover damage that has resulted from the improper installation or use of the product. The warranty does not cover damage by lightning, product misuse, electrical surges or acts of God.

LIMITATION OF LIABILITY

Sec-Eng Systems products are intended to reduce the risk of loss and damage to property in which the goods are installed to the extent which is practical. Sec-Eng Systems does not accept any liability for the loss or damage to property or persons in relation to goods supplied. This disclaimer is only limited to the warranty of the goods supplied and the intended use of the goods.

CONTENTS

INSTALLATION	Page
Overview Diagram	4
Wiring and Terminations	5-6
Indication Lights	7
SIM Card Installation	8
Operating Modes	9
PROGRAMMING	
Programming Method- Handset	10
Programming Method - SMS	11
Programming Method - Serial	11
Function Summary table	12
Program functions 1-6	13
Program functions 7-11	14
Program functions 12-16	15
Program functions 17-25	16
Program functions 27-53	17
SMS reports	18
SMS commands	19
CSV IP reporting	20-21
Control Room report codes	22
TESTING AND COMMISIONING	23
FAULT GUIDE	24-25
SED-64 OPTIONAL BOARDS	
Dual Serial Board	26
Single Relay Board	27
4 Way I/O Board	28
TECHNICAL SPECIFICATION	29

Installation - Overview Diagram

MODEL: SED-64 BY SEC-ENG SYSTEMS AUSTRALIA

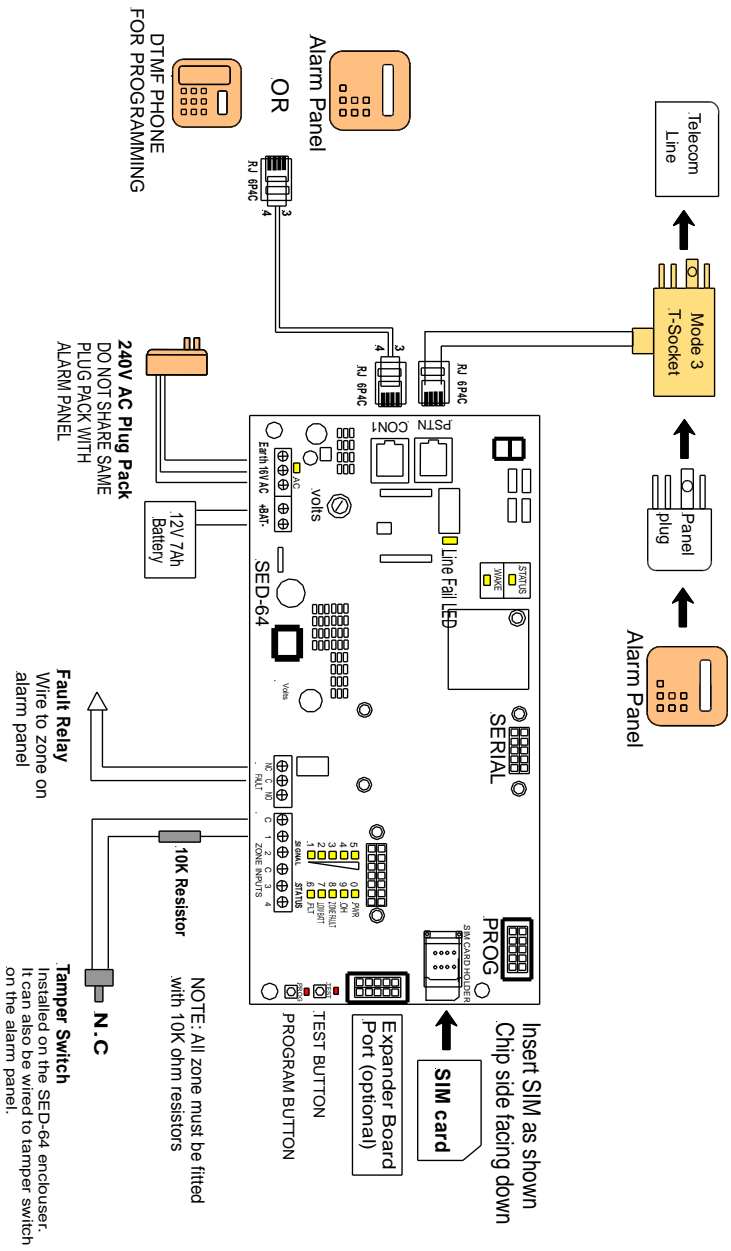

TERMINAL CONNECTIONS

<u>Terminal</u>	<u>Description</u>
POWER	
Earth	Connect to mains earth from plug pack (Green wire).
16 VAC	AC input 16V AC plug pack (Red and White wires).
+BAT-	Positive & Negative inputs for backup battery (12V, 7hr).
FAULT RELAY	
NC	Normally closed contact.
C	Common contact.
NO	Normally open contact.
ZONE INPUTS (24hr Multibreak) 10k E.O.L. (MUST BE INSTALLED)	
C	Common for Zones Inputs (negative float).
1 to 4	10k ohm end of line resistor required to common.
RJ PORTS	
PSTN	To Mode 3 T-Socket (connecting SED-64 to panel and phone line).
CON 1	Used for programming via telephone handset and for across to GSM phone line.

GSM FAULT RELAY

The SED-64 features a relay output which indicates if a general fault is present on the system. By default it is set to report the following condition:

- AC power fail for more than 1 hour
- Battery Low/Fault – below 10.7V
- Telecom line Fault - no voltage for more than 30sec (set in function 06)
- Mobile Network connection is lost for more than 8min (set in function 05)

It is recommended that this output is wire back to the alarm panel so that fault conditions is on the SED-64 are monitored.

NOTE: The default delay time for an AC power fail report is 1 hour (3600 sec). This can be change using the **?Acdly** function.

To set enter the command: **acdiy x** (x = time in seconds)

OPERATING ON 12V DC SOURCE

The SED-64 can operated on a regulated 12V DC, 300mA supply, Please note: the system will no longer have the ability to charge a backup battery.

1. Place 1A diode between one of the AC terminals and the positive battery terminal.
2. Run 12V DC into battery terminal (AC light should be on)
3. Set function 48 to 1 (disable dynamic battery test)

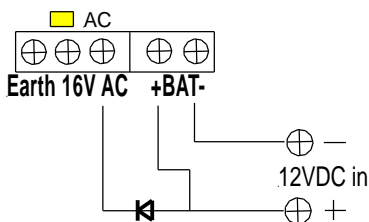

Installation - Indication Lights

LED INDICATION

LED	Normal Operation	In Programming mode
1	Signal level Low	Indicates the digit 1
2	Signal level Min	Indicates the digit 2
3	Signal level Med	Indicates the digit 3
4	Signal level Good	Indicates the digit 4
5	Signal level Best	Indicates the digit 5
6 (FLT)	GSM Fault	Indicates the digit 6
7 (BAT)	Low Battery	Indicates the digit 7
8 (ZONE)	Zone unsealed	Indicates the digit 8
9 (OH)	GSM Transmitting	Indicates the digit 9
0 (PWR)	Power On	Indicates the digit 0
13 (Fault Relay)	Fault Relay	
14 (Line Fault)	Telephone line not detected	
15 (AC)	AC OK	

FAULT LED GUIDE

A fault condition on the SED-64 is indicated when **LED 6 (FLT)** is illuminated. The signal LEDs (1-5) will provide more information on the type of fault being reported.

- LED1 ON = GSM modem fault
- LED2 ON = No SIM card
- LED3 ON = No GSM signal or registration
- LED4 ON = Not Applicable
- LED5 ON = General fault condition

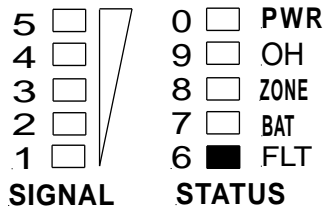

Installation - SIM Card

- 1 The SED-64 requires a MICRO size SIM card to operate. The SIM card should be activated for voice call and SMS. (data is not required)

IMPORTANT: It is not recommended to use a multi breakout type SIM. If you do, make sure the center part of the SIM is secure and does not lift off the holder when installed.

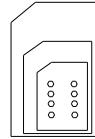

Check SIM card operation by placing in a mobile phone and testing.

If the phone requests for a pin number to be entered then the SIM card is **PIN locked**, which must be disabled before it can be used in the SED-64.

Warning: Ensure you have the correct pin number. Entering the wrong PIN will PUK lock the SIM and will then need to be returned to the vendor for reprogramming.

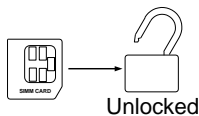

- 2 Ensure that the SIM card does work and that a call can be conducted from the mobile phone.

- 3 Test for signal strength (min 2 bars) at the panel location with the mobile phone.

- 4 Install the SIM card in the SED-64 as shown in the diagram on page 4

Installation - Operating Modes

1

FULL TIME GSM

If there is no phone line installed and the SED-64 is required to provide the alarm panel a GSM path full time.

- Program Function 07 for **GSM Full Time** (option=0 , see page 14)
- Connect alarm panel to female side of the T-socket.
- Connect RJ lead from T-Socket to the PSNT port on the SED-64
- Alternatively the alarm panel can be connected directly into the CON1 port without using the T-Socket.

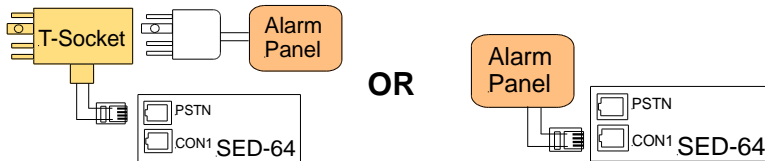

2

BASIC BACK UP SYSTEM

When a phone line is not detected, the SED-64 provides a GSM generated line for the alarm panel to dial out.

- Connect phone line to male side of T-socket.
- Connect alarm panel to female side of T-socket.
- Connect RJ lead from T-Socket to the PSNT port on the SED-64
- Wire the GSM fault relay into a 24hr zone on the alarm panel.

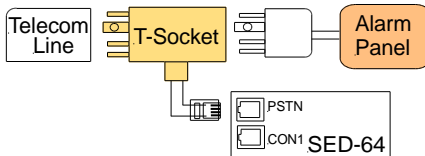

3

INTELLIGENT BACK UP SYSTEM

Along with providing the alarm panel a backup GSM path, the on-board dialler of the SED-64 will send its own system alarms/status reports to monitoring.

- Connect phone line to male side of T-socket.
- Connect alarm panel to female side of T-socket.
- Connect RJ lead from T-Socket to the PSNT port on the SED-64
- Wire the GSM fault relay into a 24hr zone on the alarm panel.
- Program functions 01, 02 & 03 on the SED-64 (see page 13)
- Provide monitoring with the SED-64 event codes list (see page 19)

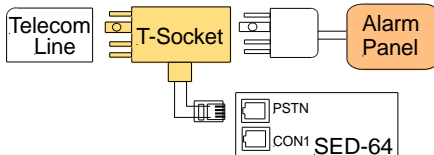

Programming – Programming Methods

There are 3 available methods to program the SED-64:

1. **Handset (Local)** – Butt phone plugged into the SED-64
2. **SMS (Remote)** – Send SMS commands from mobile phone
3. **Serial (Local)** – Optional Serial board required to connect PC

1 Programming – Using a Handset

With the SED-64 powered on, plug a standard telephone handset (**set to tone dialling**) into the RJ connector marked “CON1” (Check for a digital dial tone).

To enter Program mode:

Press and hold the **PROG Button**.

When the **PROG LED** illuminates followed by **LED 1**, release the program button.

You are now in Program Mode.

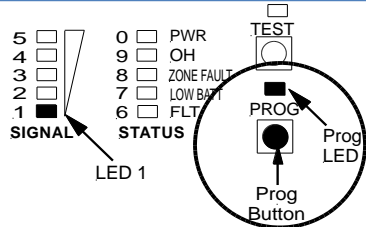

To exit Program mode:

Press and hold the **PROG Button** until LED 1 goes off, then release the program button. The PROG LED should be off and the other LEDs will return to normal.

Setting a Programming Function:

While in Program mode, set Function 01 to 9999 by keying into the phone:

***019999#**

This has now programmed the dialler account code 9999 into Function 01.

Reading a Programming Function

While in Program mode, read back function 01 by keying into the phone:

***01#**

LED 9 will flash 4 times indicating that 9999 is programmed in as the account code.

2 Programming – Using SMS

To program the SED-64 using SMS from any mobile phone, simply write a text message in the format of [*]“Function No” “Option No” [#] and then send it to the SIM card mobile phone number in the SED-64.

Attention: If the Master Code (Function 19) has been enabled, you must first send *19????# (???? = Master Code) This will allow SMS Programming Mode access for 5 minutes.

Example to program Function 01 client code to 9999 using SMS

Send the following text message ***019999#** to the SED-64. To program multiple functions, just separate messages with a comma E.G. *01999#,*02134673#

3 Programming – Using Serial PC (Optional)

An optional serial interface board is available to add on to the SED-64 which allows for a PC to be connected to the unit and programmed using a terminal window software.

Connect the SED-64 to a PC or Laptop using the DB9 serial port (labelled 1). A USB-Serial adaptor may be required if the PC does not have a serial port.

Use a terminal software program to connect with the SED-64.

uCon is a free licence program that can be downloaded from the link below:
www.umonfw.com/ucon/

Select the PC assigned com port and use the following connection settings:
Data=8, Parity=None, Stop Bit=1, Flow Control=None, Baud Rate=115200.

Once connected, hit the Enter key and you will be prompted with “Password:” Type zxcvbnm (lower case) and then the Enter key. You will then see the response “Level 3 OK”.

You are now ready to program

To program any function, simply enter the function number, followed by the value to be set

Example: to program a Function 01 (client code) with 1234, enter:

011234

Programming - Functions Summary

Function Number	Function Description	Default	Function Number	Function Number	Default
1	Client Code	0000	30	GSM Switching Number	nil
2	Primary Receiver Number	nil	31	GSM Switching Number Delay	10
3	Secondary Receiver Number	nil	32	ADEMCO Receiver Handshake Delay	2
4	GSM Internal Dialer Test Time	24	33	Modem RX Audio Level	5
5	GSM Fail Relay Trigger Time	8	34	Modem TX Audio Level	5
6	PSTN Alarm Delay	1	38	Input Debounce Delay	25
7	GSM Operation (primary or backup)	1	40	Protocol (1-2)	1
8	PABX Mode	0	41	Contact ID Event Code	140
9	Zone 1-4 Lockout Control	0	42	Voice Call Duration Limit	4
10	ADEMCO Event Codes	0	43	Input Termination	0
11	Software Version: Loader Version	049:0	44	Band Selection	nil
12	SMS Phone 1	nil	45	Network technology 2=GSM, 3=3G 4=4G (set by Hardware)	4
13	SMS Phone 2	nil	46	Report Path	652
14	SMS Phone 3	nil	47	Web Server Enables	0
15	SMS System Reporting	0	48	External DC Power to +BAT-	0
16	SMS Zone Reporting	0	49	20+21 on, Use Panels PH Number	0
17	Secure Zone Inputs	0	50	Set 33 and 34 together	(33=5, 34=5)
18	Secure Zone SMS Confirmation	0	51	SMS Server Enable	0
19	Master Code	0000	52	Voice Call Notify Ring time in (sec) Must set function 01, 02	0
20	ADEMCO Receiver Enable	0	53	OH Alarm delay (sec)	0
21	ADEMCO Receiver Forward Enable	0	54	OH Alarm number	0
22	ADEMCO Receiver Output Enable	0	55	Modem Re-register attempts	3
23	Auto Answer	0			
24	Fault Relay Control	0			
25	External Inputs Enable	0			
26	Restricted Access Enable	0			
27	SMS Phone 1 Zones	12345678			
28	SMS Phone 2 Zones	12345678			
29	SMS Phone 3 Zones	12345678			

Function 01 - Client Code

This sets the account code that the SED-64 will use when using its on-board dialler to report to the Monitoring Company.

Options:

Any 4 digit number

Example: *019999#

Function 02 – Primary Receiver Number

This sets the primary phone number that the SED-64 will dial when using its on-board dialler to report to the Monitoring Company.

Options:

Any phone number up to 18 digits

Example: *021234567#

Note: Make sure the phone number can be dialled from a mobile phone.

Function 03 – Secondary Receiver Number

This sets the secondary phone number that the SED-64 will dial when using its on-board dialler to report to the Monitoring Company if unable to make a valid connection using the primary receiver number.

Options:

Any phone number up to 18 digits

Example: *031234567#

Function 04 – GSM Internal Dialer Test Time Default = 24hr(Daily)

Change the time between the SED-64 test call reports (sector 253). The time is in Hour intervals.

0 = No test call reports
24 = Test Call every day
168 = Test call once a week

To force a test call press and hold test button for 7 sec. Test LED will flash. This will send a test call at the time (see page 18)

Options:

From 0 to 168 Hours

Example: *0424#
(sets a test call every 24 hours)

Function 05 - GSM Fail Relay Trigger Time Default = 8 minutes

This sets the time between the SED-64 detecting that the GSM signal is not present and when the fault relay activates. This is important for times when the GSM signal can occasionally drop out for short periods but it is not necessary to send an alarm as it restores within a few minutes.

Options:

From 1 to 8 minutes

Example: *055#
(waits 5 minutes before the fault relay activates)

Function 06 - PSTN Alarm Delay

Default = 1 (30 seconds)

This sets the time between the SED-64 detecting that the PSTN line voltage is low or not present and when a PSTN trouble / fail alarm is reported. This is important in areas where the PSTN line voltage can drop due to loading but the line is still functional and restores normally.

Options:

0 = 50 seconds
1 = 30 seconds

Example: *060#

Function 07 - GSM Operation

Default = 1

Sets the way the SED-64 operates as a backup or other modes.

GSM FT=GSM operates full time (no phone line) \longleftrightarrow 0 = GSM FT (No phone line)
GSM BU=GSM operates as a back up unit \longleftrightarrow 1 = GSM BU (default)
GSM FT / PSTN BU=GSM is used full time but will \longleftrightarrow 2 = GSM FT / PSTN BU
switch

PSTN line if the GSM fails.

This requires a dedicated PSTN line

Options:

Example : *071#

Function 08 - PABX Mode

Default = 0

If the Alarm Panel PSTN line is connected through a PABX then the receiver phone number will have an outside line number as a prefix (usually 0). In PABX mode the SED-64 will ignore this first digit when it dials out on the GSM network as it is not required.

Options:

0 = Dial all numbers
1 = Ignore the 1st Digit

Example : *080#

Function 09 - Zone 1 – 4 Lock Out Control

Default = 0

This function provides a lockout feature on the 4 SED-64 zone inputs. Enable this to block reporting of rapid multiple activations on a zone input.

Options:

0 = No Lockout
1 = Enter in minutes (1-30)

Example : *091#

Function 10 – Ademco Event Codes

Default = 0

Sets the starting number for the SED-64 onboard dialler reporting codes. In most cases , reporting codes 250 and above are OK to use as the alarm panel does not need this many codes but in larger systems where code 250 is in use, the report codes for the SED-64 can be changed to 450 and above. Also Option 2 allows for Ademco standard event codes for power fail, low batt, PSTN Fail and GSM Test. Refer to page 20 for at list of report codes and event codes.

Options:

0 = Starting at 250 (default)
1 = Starting at 450
2 = Standard Event Codes

Example : *100#

Function 11 - Software Version

Displays the software version of the SED-64 program code. The read-back will be a 2 digit number.

No Options

(Read-back only)

Example : *11#

Function 12 - Mobile phone 1

The SED-64 can report events via SMS to 3 mobile phones (see page 19) **Note:** we only recommend this option for non-critical alarms or for secondary monitoring purposes due to the nature of the SMS delivery service. Enter the number of the first mobile phone to report to. If left empty Mobile Phone Reporting is disabled. Send 0000 to default

Options:
Any phone number
Up to 18 digits

Example: *120406991992#

Function 13 - Mobile phone 2

Enter the number of the second mobile phone for the SED-64 to report events to. Leave this option blank if no second mobile is needed. Send 0000 to default

Options:
Any phone number
Up to 18 digits

Example: *130406991993#

Function 14 - Mobile phone 3

Enter the number of the third mobile phone for the SED-64 to report events to. Leave this option blank if no third mobile is. Needed Send 0000 to default

Options:
Any phone number
Up to 18 digits

Example: *140406991994#

Function 15 - SMS System Reporting

Default = 0

This function determines what SMS System Messages are sent by the SED-64. SMS System messages are AC Fail, Low Battery, GSM Test and Fail to Communicate.

Options:
0 = Disable SMS Messages
1 = Enable Option 1
2 = Enable Option 2

Option 1 = Sends all system messages to mobiles
Option 2 = Sends all system messages except GSM Test

Example: *150#

Function 16 - SMS Zone Reporting

Default = 0

Enable this function if you would like an SMS message sent to the mobile phone number,1,2,3 When zones 1- 4 are activated. See page 19 for changing the text of the SMS message.

Options:
0 = Disabled
1 = Enabled

Example: *160#

Function 17 - Zone Input Configuration

Default = 0

Sets the operation of the 4 Zone Inputs on the SED-64

- Option 0 = Zones 1-4 24 hour inputs
- Option 1 = Zones 1-4 armed/disarmed via SMS
- Option 2 = Zones 1-3 are 24 Hr but Zone 4 is a control type and switches PSTN over to GSM

Options:

- 0 = Option 0
- 1 = Option 1
- 2 = Option 2

Example: *171#

Function 18 - SMS Zone Arming Confirmation

Default = 0

Enables confirmation SMS Message of arm / disarm of Zones 1- 4 (Function 17 = 1) See page 19 for more details

Options:

- 0 = Disabled
- 1 = Enabled

Example: *181#

(SMS Confirmation Enabled)

Function 19 - Master Code

Default = Nil

If you want to restrict access to the SED-64 programming, enter a 4 digit PIN number. You will have to then enter *19pin# before you can reprogram or gain access to the SED-64 once set (by either Manual Mode or SMS Programming Mode). Once the *19pin# is entered it will allow you into the programming mode for 5 minutes.

Options:

Any 4 digit number

Example: *191234#

(Sets Master Code to 1234)

Function 24 - Fault Relay

Default = 0

Sets the operation of the Fault Relay

- Option 0 = Relay operates in normal mode
- Option 1 = Inverts relay to operate in fail safe mode
- Option 2 = Disables relay as fault relay and relay is controlled via SMS as Relay 0.
(see page 19 for SMS output control)

Options:

- 0 = Option 0
- 1 = Option 1
- 2 = Option 2

Example: *242#

(Relay controlled by SMS)

Function 26 – Mobile Restricted Access

Default = 0

Sets the SED-64 to only respond to phone numbers that have been programmed in functions 12,13 and 14. All other phone numbers will be ignored.

Options:

- 0 = No restricted access
- 1 = Restricted access

Function 27 – SMS Phone 1 Zones

Default = 12345678

This determines what zone number will report (via SMS) to the mobile number in Function 12

Function 28 – SMS Phone 2 Zones

Default = 12345678

This determines what zone number will report (via SMS) to the mobile number in Function 13

Function 29 – SMS Phone 3 Zones

Default = 12345678

This determines what zone number will report (via SMS) to the mobile number in Function 13

Function 42 – Voice Call Duration Limit

Default = 4

This set time limit after which the SED-64 will end any phone call being conducted. The Value is set in minuets.

Function 48 – DC Power

Default = 0

This enables the unit to operate on external DC supply. It disables the AC input and backup battery monitoring. See page 6.

Options:
0 = Normal operation
1 = Operate on DC

Function 53 – OH Alarm Delay

Default = 0

This OH Alarm feature allows for the SED-64 to be set up to auto dial a programmed phone number when a handset connected to the unit is taken off hook. The OH Alarm Delay sets the delay time (in seconds) between the handset being taken off hook and the number being dialed.

Function 54 – OH Alarm Number

Default = 0

This OH Alarm Number is the phone number which the SED-64 will auto dial when the handset is taken off hook.

SMS Reports

NOTE: SMS commands must be as shown. (MUST BE IN CAPITALS)

From any mobile phone, simply send an SMS text message as shown below to the SED-64 mobile phone number and it will send back an SMS message with the requested report information.

Available SED- 64 SMS reports

- ?P = Request SED-64 program setup
- ?S = Request SED-64 current status
- ?H = Request History - Displays the last 20 events
- ?T= Force test call now to control room

?S

Send a **?S** to request the current status of the SED-64. The current status for the AC power, PSTN, Battery and GSM Signal Strength will be shown.

NOTE: If a Master Code has been set in the SED-64, you will not get a response from any command (except for ?S). See Function 19 for information on the Master Code setup.

?P

Send a ?P to request the current program function settings. See page 12 for the list of function numbers and options.

?H

Send a ?H to request a list of the last 20 events that have occurred on the SED-64. The first event listed is the oldest.

LEGEND

DT = GSM Dialler test	i1 = input 1	TO = timed out	BF= battery fail
LB = Low battery	i2 = input 2	PB = program via button	GF = GSM fail
PF = AC Power fail	i3 = input 3	PS = program via SMS	IPR= fail IP address
SF = GSM signal fail	i4 = input 4	iD = inputs disarm	?BT= boot
LF = PSTN line fail	DF = Dialler fail	iA = inputs armed	MCF = modem fail
SS= System start			

?T

When a ?T is sent to the SED-64 it will force a test call to the control room and will reset the Test Call timer to start from this time. This can also be done by holding the TEST button down for 10 seconds.

SMS Commands

The following SMS commands control additional features of the SED-64

NOTE: SMS commands must be as shown. (case sensitive)

Zone Arm and Disarm Feature

The SED-64 zone inputs can be armed and disarmed by sending the following SMS messages. This command will arm/disarm **all** zone inputs.

Important: It is advisable to program functions 16,17 & 18 to Option 1 and program the mobile numbers into function 12, 13 & 14 if necessary.

Arm / Disarm Commands

?ON = Arms all 4 zones (must be upper case)

?OFF = Disarms all 4 zones (must be upper case)

Zone Inputs Individual Text Labels

The SED-64 zone inputs can be programmed with individual text labels for SMS reporting.

Text Message Format

in<State><Input><Text>

To Clear: send without <Text>

Parameter Description:

<State> = "a" for alarm and "r" for restore

<Input> = Zone Input Number

<Text> = Max 16 Characters (including spaces)

Example:

ina1front door will program Zone 1 alarm with "front door alarm" (MAX 16 CHAR)

Relay Control

To control the SED-64 Output Relays, send an SMS message as follows:

Text Message Format

out<Relay>on {Timer}

out<Relay>off {Timer}

Parameter Description:

<Relay> = Relay Number

{Timer} = Optional timer value in Hours [h] minutes [m] and seconds

Example (for Relay 5)

out5on = Turns Relay 5 on (indefinitely)

out5off = Turns Relay 5 off (indefinitely)

out5on2 = Turns Relay 5 on for 2 seconds (if relay is off)

out5off2 = Turns relay 5 off for 30 seconds (if relay is on)

Note: Relays 1 - 4 are via an expander board, which must be enabled in programming (see function 25). Relay 5 is onboard as standard and Relay 0 can be enabled if the fault relay is not required (see function 24).

CSV IP ALARM PROTOCOL

The SED-64 is capable of reporting alarms via the CSV IP protocol to monitoring companies providing this service.

CSV alarms can be generated by connecting an ADMCO alarm panel to the SED-64 or from SED-64 itself via the input zones or system fault conditions.

Setting up CSV reporting can be done by SMS commands or connecting to a PC using the option serial board adaptor.

The Command **?CSV** will report all the CSV related setting currently configured on the SED-64.

To set up:

1. Set the 4 digit client code in the field **CSVclient ###**
Example: **CSVclient 8888**
2. Set the IP address and port of the monitoring company's CSV server using the command **CSVIP IP:PORT**
Example: **CSVclient 123.101.0.5:5000**
3. Set the **Path** function to A
Example: **Path A**
4. By default the SED-64 will use TCP for communication, if UDP is required then use the commanded **CSVTCP**
Example: **CSVTCP 1** for TCP (default)
CSVTCP 0 for UDP
5. Set the **APN** according the sim card service used in the SED-64.
Example:
For Telstra use **APN telstra.internet**
For Optus use **APN connect**
For Vodafone use **APN live.Vodafone.com**
6. If required by the monitoring company, a username and password can be set up for CSV authentication. Otherwise leave as the default user and pass
Example: **CSVUSER #####**
CSVPASS #####

CSV IP ALARM PROTOCOL

7. Enable the data communication on the SED-64 by setting **GPRS** to 1
Example: **GPRS 1**

At this point the SED-64 will start reporting via alarm via CSV.
To test use the command **?T** to activate a test alarm and check with the monitoring company.

If using the SED-64 to report alarms from an ADEMCO contact ID alarm panel then there are some additional functions which need to be set.

With this set up the SED-64 will act as a local contact ID receiver and kiss off the alarm panel, then convert and send the ADEMCO alarms via IP to the monitoring company.

To set up:

8. Enable the ADEMCO receiver feature on (set function 20 to 1)
Example: **201**
9. Enable the ADEMCO receiver forward feature on the (set function 21 to 1)
Example: **211**
10. Connect the alarm panel to the SED-64 as shown

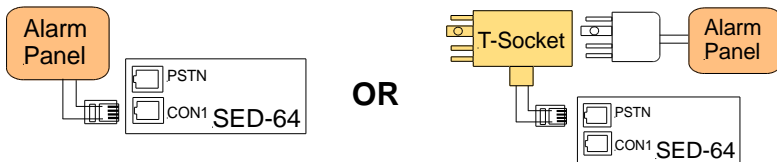

At this point the alarm panel will be able to report contact ID alarms to the SED-64 which will then forward the alarm information via CSV to the monitoring company.
To test activate the alarm panel and check with the monitoring company..

Control Room report codes

The SED-64 on-board dialler will send Ademco 140 contact ID codes followed by the point number e.g. 250. This should be treated the same as a sector 250 like any standard alarm panel. E.g Tecom Challenger

GSM Dialler Ademco Codes			
<u>Alarm event</u>	<u>Function 10 = 0</u>	<u>Function 10 = 1</u>	<u>Function 10 = 2</u>
AC power fail after 1 hr	140 Sector 250	140 Sector 450	301 Sector 000
low battery < 10.7v or no battery	140 Sector 251	140 Sector 451	311 Sector 000
Telecom line fail	140 Sector 252	140 Sector 452	351 Sector 000
GSM test	140 Sector 253	140 Sector 453	602 Sector 000
Zone Input 1	140 Sector 254	140 Sector 454	140 Sector 001
Zone Input 2	140 Sector 255	140 Sector 455	140 Sector 002
Zone Input 3	140 Sector 256	140 Sector 456	140 Sector 003
Zone Input 4	140 Sector 257	140 Sector 457	140 Sector 004
Zone Input 5 (expander)	140 Sector 258	140 Sector 458	140 Sector 005
Zone Input 6 (expander)	140 Sector 259	140 Sector 459	140 Sector 006
Zone Input 7 (expander)	140 Sector 260	140 Sector 460	140 Sector 007
Zone Input 8 (expander)	140 Sector 261	140 Sector 461	140 Sector 008
	DEFAULT		
Note: restores are also sent for each code			

Testing and Commissioning

Please perform the following tests after completing the installation of the SED-64.

Testing the SED-64 Basic GSM Backup

1. With the unit powered up and working (STATUS LED flashing and at least 3 bars of signal strength), disconnect the T-socket from incoming telecom line.
2. The unit will detect a line fault after a short period (LINE FAIL LED will illuminate) and then, after the PSTN fail detect time of 30 sec, the fault relay will activate (unless function 24 is not at the default). Also, if the SED-64 is in intelligent mode, a PSTN line fail will be reported to the Alarm Company by the SED-64.
3. Now trigger an alarm on the customers alarm panel. As the alarm panel dials out, it will communicate over the GSM network through the SED-64. On the SED-64 the OH light (LED 9) will come on solid, indicating that the alarm panel is communicating over the GSM network.
4. Once the Alarm Panel has successfully reported the alarm, it will hang up. Check with the Monitoring Company that they received the correct alarm report. If the alarm panel does not communicate successfully check the Fault Guide section (page 23) to diagnose the problem.
5. Once testing is complete, plug the telephone line back into the T-socket. The line fail LED should go out and after about 1 minute, the fault relay will deactivate.

Testing the SED-64 Intelligent GSM Backup

1. Make sure Functions 1, 2 & 3 on the SED-64 are programmed and that the SED-64 is working (STATUS LED flashing and at least 3 bars of signal strength).
2. Activate then re-seal Zone 1 on the SED-64. The OH light (LED9) will flash while the SED-64's internal dialler is dialling. The SED-64 will report Sector 254 to the monitoring company (this should take less than 10 seconds).
3. Disconnect the T-socket from incoming telecom line.
4. The line fail LED will illuminate and, after about 20 seconds, the OH light (LED 9) will start flashing as the SED-64 reports a Sector 252 to the Monitoring Company. Once the OH light stops flashing the fault relay will activate.
5. Now plug the T-socket back into phone line and the SED-64 will send a PSTN restore through.
6. Check with the Monitoring Company that they received the correct alarm reports. (Zone 1 set/restore and PSTN set/restore). If the alarm panel does not communicate successfully, check the Fault Guide section (page 23) to diagnose your problem.

Fault Guide

Before calling for support please look to see if your problem is listed below.

1. The fault light is on or flashing:

Remove the power from the SED-64, then remove the SIM card and put it in a working 4G/3G mobile phone. Turn the phone on. If the phone asks for a PIN number, the SIM card is pin code locked. Go to phone set up/security settings and turn the PIN request off. Power off the phone then on again. It should not ask for a PIN. Put the phone next to the SED-64 antenna location and make sure you have at least 3 bars of signal on the phone. Making sure the power is still off on the SED-64, re-insert the SIM card and power it up. When the SED-64 finds signal, the wake LED should be on with the status LED flashing and the signal meter will show signal.

2. I cannot program the SED-64:

With the SED-64 powered up, put a standard PSTN phone into "CON1" on the SED-64 board. Press and hold the "PROG Button" until LED1 lights up. Remove your finger immediately from the button. The "PROG LED" should stay illuminated. First, do a LED Test by pressing the * (Star key) on the phone. LEDs 1,3,5,6,8 & 0 should light. Now Press the # (hash key), the LEDs 2,4,7 & 9 should light. If no LEDs light up, check that the phone you are using is set to **Tone (DTMF)** dialing and not pulse (Decadic). If the LEDs do light up, do a read back of function 01 by keying on the phone ***01#**. The LEDs should illuminate in order of the client code. If the unit has not been programmed before, the client code should be 0000. If no LEDs illuminate then the SED-64 may have a Master Code (Function 19). You can now try defaulting the SED-64 (but make sure you know all the program settings before doing this, as you will need to re-program the SED-64 from scratch!) Default the unit by being in program mode and entering ***996464#**. To check if it is defaulted OK, do a read back of function 01 again. LED 0 should flash 4 times indicating an account code of 0000.

3. I do not receive a response via SMS:

- Check that you have the correct mobile number for the SIM card in the SED-64.
 - Check that the SIM card in the SED-64 has the ability to send SMS (test in a mobile phone).
 - Check if a MASTER CODE (Function 19) has been set.
- If the SED-64 responds to a **?S** but none of the other SMS commands then it suggests that a Master code has been programmed on this unit.
To gain access to the programming fields this code must be entered first.
Send SMS **19????** (???? = Master Code).
If it is correct the SED-64 will respond with the message **"PIN OK"**.
This will then enable full access to the SED-64 for 5 minutes before re-activating the Master Code request.

4. The SED-64 on-board dialler is not communicating

- Check if Functions 01, 02 & 03 are programmed correctly.
- Check if the OH LED flashes when triggering an input or pressing the test button on the SED-64 (OH LED activity indicates the system attempting to make a call).
- If the OH LED is not flashing, check that the zones are armed.
- Put a phone into CON1 and when the OH LED is flashing, pick up the handset and listen in for comms to the Control Room. If you hear comms check with the Control Room that they are monitoring the correct Contact ID codes.

Fault Guide

5. I Programmed the SED-64 OK but the Alarm Panel will not communicate with the Control Room via GSM

To test the GSM communications, plug a standard phone or phone butt into “CON1” and pickup the handset (off-hook the butt). You should hear dial tone generated by the SED-64. If you do not hear a dial tone then make sure:

1. The SED-64 is powered up
2. You are plugged into “CON1”
3. The phone you are using is in good working order.

If you do hear dial tone, make a call to the control room using the same number that is programmed into the alarm panel/SED-64. If you cannot get through, try calling your mobile phone. If your mobile phone rings then the SED-64 is good, so check that the control room number is correct.

If when you called the control room number you heard the Ademco BEEP BEEP, then the control room number and the SED-64 are good and the problem is usually in the way the alarm panel dialler communicates.

Firstly, check that the Alarm Panel and the SED-64 are using their respective separate plug power packs. A single plug pack should not be used to power both units. Make sure the SED-64 is powered by the plug pack provided by Sec-Eng Systems. Next, with the butt still plugged into “CON1”, unplug the T socket from the phone line. Wait for line fail LED to activate then, activate an input on the Alarm Panel. Listen in on the call while the Alarm Panel communicates to the Control Room by picking up the butt when the OH (LED 9) is illuminated.

If you can hear the panel get through but the control room won't kiss off (you will hear the panel retry 2 or more times) then it is probably necessary to adjust the Gain Control on the SED-64. To adjust the gain, set function 33 and 34 to a 9 (max level). See Page 12 for function list.

6. The Alarm Panel is working on GSM but Control Room is not receiving the alarms:

Put a telephone or phone butt into “CON1” and listen to the Alarm Call by picking up the handset when the OH (LED 9) is on. Do you hear a kiss off signal after the panel has sent through the alarm information? If you do, but the control room says that they didn't receive the alarm, then the number may be re routed. Ask the control room for a non-1300 or another 1300 number to try.

SED-64 Dual Serial Board (DSB) - Optional

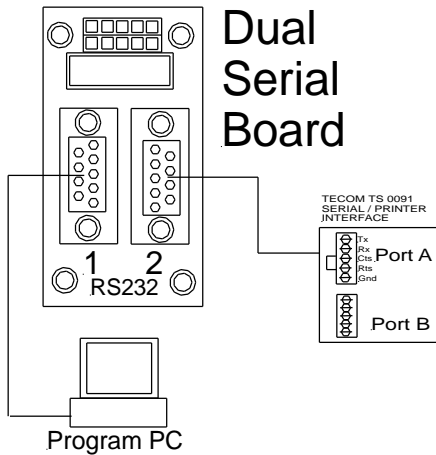

Dual Serial Board

This interface is used to allow serial comms for the SED-64

Port 1 is used so you can program the SED-64 via a terminal window (115k 8-N-1)

Port 2 is used for upload/download via a circuit switched data connection on the SIM card (not supported on 4G)

INSTALLING THE BOARD: Fit onto the SED-64 board in the position shown on page 4 (the top 10 way connector on the SED-64 marked SERIAL)

PROGRAMMING

Connect a PC/laptop using a straight through serial connection onto serial port 1. This allows for programming and set up for the SED-64
Connect using Ucon/HyperTerminal software at 115k 8-N-1 to Port 1
Hit enter and password shall appear. Now type **zxcvbnm** in lower case.
You are now in the program mode Type **?S** to confirm the SED-64 is connected.

SET UP PORT 2

With PC still connected, type the following:

CSDSPD=4800 (enter)

CSDRING=2 (enter)

CSDEN=1 (enter)

Now type ?CSDEN and the setting should be the same as you have just typed.

The SED-64 is now set up to receive circuit switched in-coming data calls.
Wire up PORT 2 now to the TECOM TS 0091 as shown with lead provided.

SED-64 Single Relay Board (SRB) – Optional

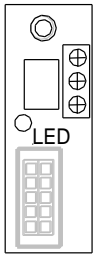

Single Relay Board

INSTALLATION

1. Power off the SED-64
2. Remove mounting screw top RH side
3. Install 10 mm hex stand-off
4. Fit relay board as shown below
5. Re-fit the screw to secure

Part :SED-SRB
Control via SMS

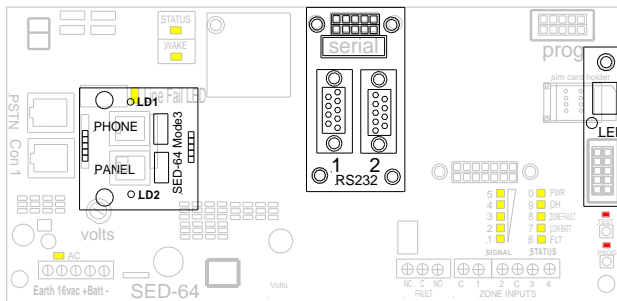

Here

TESTING

To test this board, SMS the SED-64 the following:

OUT1ON

This will now turn the relay on. See LED on the board

OUT1OFF

will now turn it off

SED-64 4 way I/O Board - Optional

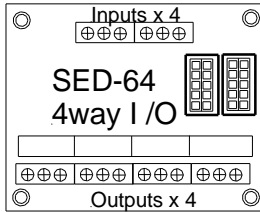

This board allows for an extra 4 inputs and 4 outputs operating from the SED-64 v009 onwards

Part: SED-4 Way I/O
Extra 4 relays and inputs that can be multi-chained

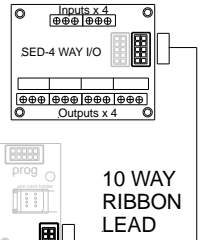

INSTALLATION PROCESS

1. Power down the SED-64
2. Fit card as shown
3. Fit 4 X 10k EOL into Inputs
4. Set all dip switches OFF
5. Power up SED-64

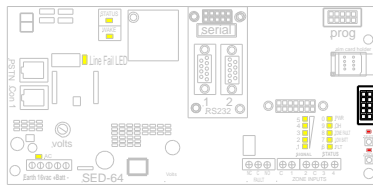

A maximum of four I/O boards can be connected to a single SED-64 giving a total of 20 inputs and 16 outputs.

Set the Dip switches for the I/O boards as follows:

I/O Board 1	ALL OFF
I/O Board 2	4 ON
I/O Board 3	3 ON
I/O Board 4	3 & 4 ON

The extra input zones will be labeled 5-20

I/O Board 1	Zone 5-8
I/O Board 2	Zone 9-12
I/O Board 3	Zone 13-16
I/O Board 4	Zone 17-20

The extra relays will be labeled 5-20 and are controlled using the same commands as the first 4 relays (see page 19).

I/O Board 1	Output 5-8
I/O Board 2	Output 9-12
I/O Board 3	Output 13-16
I/O Board 4	Output 17-20

Technical Specifications

Dimensions:	235 x 250 x 80mm (Housing)
SIM Required:	MICRO size, SMS enabled
Power Pack Input:	230-240VAC
Power Pack Output:	16V AC 1.5A
External Power Supply:	12V DC
Current draw:	250mA, 12V DC
Backup Battery:	12V 7Ah gel cell (Not included)
POTS interface:	RJ12
Line voltage:	42V
Antenna connector:	SMA Female
Antenna supplied:	3dBi Omni directional
Modem:	UBLOX LARA R6 Cat-1 LTE
Network Connectivity:	VoLTE 4G with 3G and 2G fallback LTE frequency Bands B1(1920- 2170MHz), B3(1710-1880MHz), B5(824-894MHz), B7(25002690MHz), B8(880-960MHz), B28(703-803MHz) 3G frequency bands B1(2100 MHz), B4(1700 MHz)

Certification

PTCRB, GCF, R&TTE & CE (Europe), FCC (US), IC (Canada), Giteki (Japan), A-tick & RCM (Australia), IDA (Singapore), Anatel (Brazil), NCC (Taiwan), CCC (China), KCC (S. Korea), AT&T (USA), DoCoMo, Softbank (Japan), Telstra (Australia), Vodafone (All Vodafone networks), Telecom NZ, Rogers, Bell Mobility, Telus (Canada), SKT (S. Korea), ICASA (S. Africa), AT&T (US).



ACMA - RCM Certified

Technical Support

Contact Sec-Eng Systems for technical support

Phone 02-9524 9952

Mon – Fri 9.00AM to 5.00PM AEST

WWW.SECENG.COM.AU